

# COBRA

MODEL: CHIP700L (DR-GS-350H)

## COBRA PETROL CHIPPER OWNER'S MANUAL

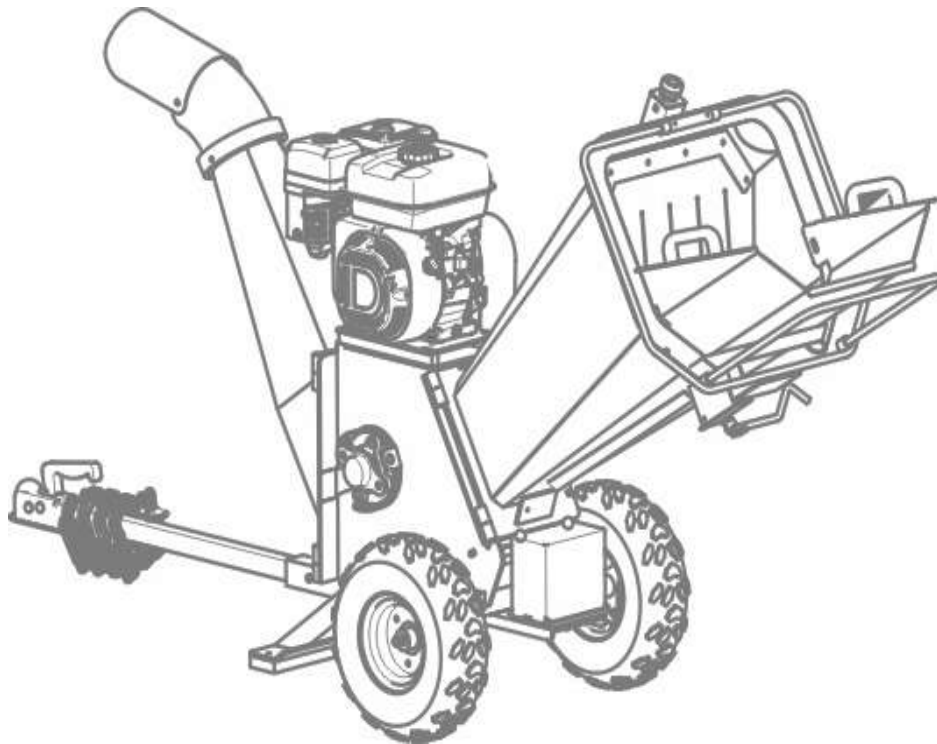

### IMPORTANT

Read safety rules and instructions carefully before operating equipment.

**Cobra Garden Machinery**

Henton and Chattell Ltd., London Road, Nottingham NG2 3HW UK

[www.cobragarden.co.uk](http://www.cobragarden.co.uk)

# Table of Contents

PART I: General Safety Rules.....	3
PART II: Familiar with the Wood Chipper.....	9
PART III: Operating the Wood Chipper.....	10
PART IV: Maintaining the Wood Chipper.....	12
PART V: Troubleshooting and Parts List.....	13
PART VI: Warranty and Environment.....	16
PART VII: Assembly Instruction.....	17

## Conventions used in this manual

---

### **WARNING**

This indicates a hazardous situation, which, if not avoided, could result in death or serious injury.

---

---

### **CAUTION**

This indicates a hazardous situation, which, if not avoided, could result in minor or moderate injury.

---

---

### **NOTICE**

This information is important in proper using of your machine. Failure to follow this instruction could result in damage to your machine or property.

---

## Additional Information and Potential Changes

We reserve the right to discontinue, change, and improve its products at any time without notice or obligation to the purchaser. The descriptions and specifications contained in this manual were in effect at printing. Equipment described within this manual may be optional. Some illustrations may not be applicable to your machine

# PART I: General Safety Rules

## Safety Labels Found on Your Unit



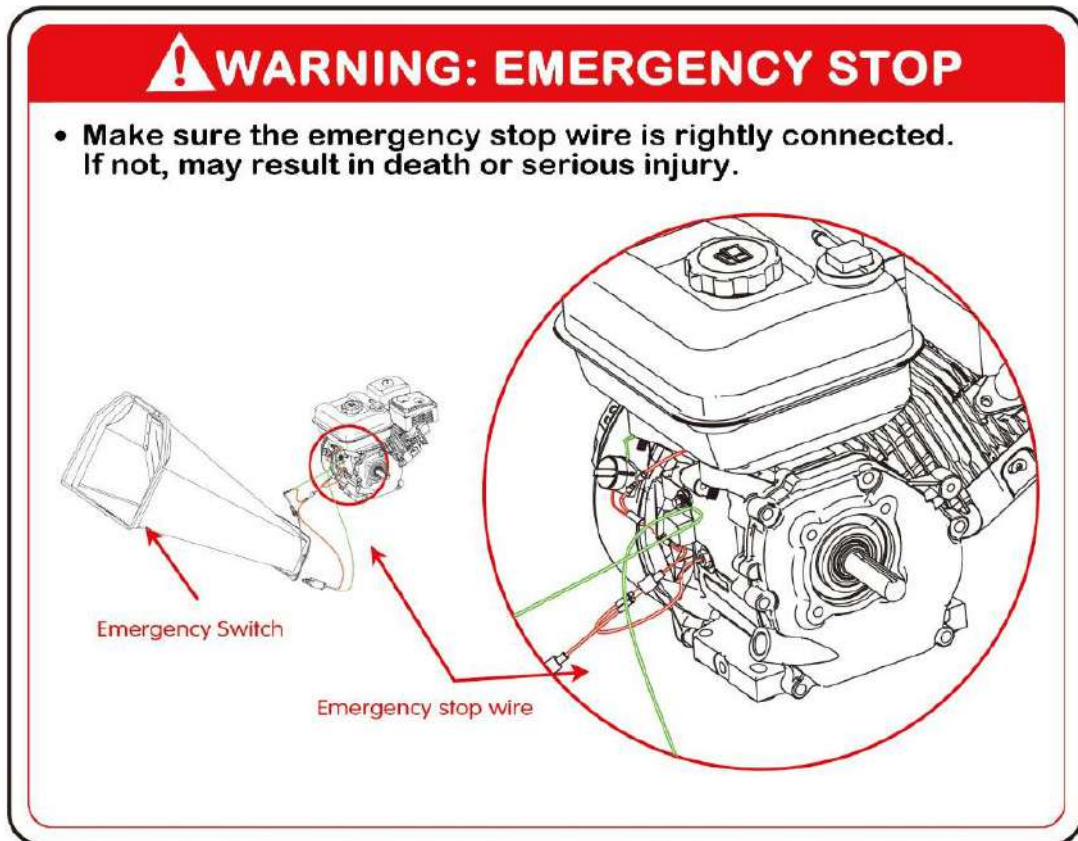

Should make sure the emergency stop switch is available before every use. Or may result in serious injury even death.

## **! WARNING**

Read this Safety & Operating Instructions manual before you use the Wood Chipper. Become familiar with the operation and service recommendations to ensure the best performance of your machine.

## **Propose**

## **! CAUTION**

This machine is designed solely to chip wood and must not be used for any other purpose.

It should only be used by trained operators who are familiar with the content of this manual. It is potentially hazardous to fit or use any parts other than your dealer parts. The company disclaims all liability for the consequences of such use, which in addition voids the machine warranty.

## Before using the wood chipper

---

### NOTICE

- A. Operators must be fully trained before using this machine.
  - B. User Manual is read and understood.
  - C. Machine is positioned on level ground, all guards are fitted and in good condition.
  - D. Blades are in good condition and secure. All blades are sharpened or replaced in sets.
  - E. All fasteners are checked for tightness.
  - F. Only WOODEN materials free of nails etc. are fed into the machine.
  - G. Emergency stop wire is rightly connected and the switch is functional.
  - H. Fire extinguisher is available on site.
- 

## When using the wood chipper

---

### NOTICE

- A. Always feed from the side.
  - B. It is better to have a second trained operator within easy reach of the machine.
  - C. Maintain strict discipline at all times and service machine at specified periods.
  - D. Note direction of discharge chute and if necessary note the wind direction to prevent debris from being blown into highway or where it could affect members of the public.
  - E. DO NOT put any part of your body into the in-feed chute while the machine is running.
  - F. DO NOT operate the machine whilst under the influence of alcohol or drugs.
  - G. DO NOT operate inside a building or confined space or Climb on the in-feed chute.
- 

## Protecting Yourself and Those Around You

---

### WARNING

This is a high-powered machine, with moving parts operating with high energy. You must operate the machine safely. Unsafe operation can create a number of hazards for you, as well as anyone else in the nearby area. Always take the following precautions when using this machine:

- A. Keep in mind that the operator or user is responsible for accidents or hazards occurring to other people, their property, and themselves.
- B. Always wear protective goggles or safety glasses with side shields while using the Wood Chipper to protect your eyes from possible thrown debris.
- C. Avoid wearing loose clothing or jewelry, which can catch on moving parts.
- D. We recommend wearing gloves while using the Wood Chipper. Be sure your gloves fit properly and do not have loose cuffs or drawstrings.
- E. Wear shoes with non-slip treads when using your Wood Chipper. If you have

safety shoes, we recommend wearing them. Do not use the machine while barefoot or wearing open sandals.

- F. Wear long trousers while operating the Wood Chipper.
  - G. Keep bystanders at least 50 feet away from your work area at all times. Stop the engine when another person or pet approaches.
- 

## Safety for Children and Pets

---

### **WARNING**

Tragic accidents can occur if the operator is not alert to the presence of children and pets. Children are often attracted to the machine and the chipping activity. Never assume that children will remain where you last saw them. Always follow these precautions:

- A. Keep children and pets at least 50 feet from the working area and ensure they are under the watchful care of a responsible adult.
  - B. Be alert and turn the machine off if children or pets enter the work area.
  - C. Never allow children to operate the Wood Chipper.
- 

## Safety with Petrol - Powered Machines

---

### **WARNING**

Petrol is a highly flammable liquid. Petrol also gives off flammable vapor that can be easily ignited and cause a fire or explosion. Never overlook the hazards of petrol. Always follow these precautions:

- A. Never run the engine in an enclosed area or without proper ventilation as the exhaust from the engine contains carbon monoxide, which is an odorless, tasteless, and a deadly poisonous gas.
- B. Store all fuel and oil in containers specifically designed and approved for this purpose and keep away from heat and open flame, and out of the reach of children.
- C. Replace rubber fuel lines and grommets when worn or damaged and after 5 years of use.
- D. Fill the petrol tank outdoors with the engine off and allow the engine to cool completely. Don't handle petrol if you or anyone nearby is smoking, or if you're near anything that could cause it to ignite or explode. Reinstall the fuel tank cap and fuel container cap securely.
- E. If you spill petrol, do not attempt to start the engine. Move the machine away from the area of the spill and avoid creating any source of ignition until the gas vapors have dissipated. Wipe up any spilled fuel to prevent a fire hazard and properly dispose of the waste.
- F. Allow the engine to cool completely before storing in any enclosure. Never store a machine that has petrol in the tank, or a fuel container, near an open flame or spark such as a water heater, space heater, clothes dryer or furnace.

- G. Never make adjustments or repairs with the engine running. Shut down the engine, disconnect the spark plug wire, keeping it away from the spark plug to prevent accidental starting, wait 5 minutes before making adjustments or repairs.
  - H. Never tamper with the engine's governor setting. The governor controls the maximum safe operation speed and protects the engine. Over-speeding the engine is dangerous and will cause damage to the engine and to the other moving parts of the machine. If required, see your authorized dealer for engine governor adjustments.
  - I. Keep combustible substances away from the engine when it is hot.
  - J. Never cover the machine while the muffler is still hot.
  - K. Do not operate the engine with the air cleaner or the carburetor air intake cover removed. Removal of such parts could create a fire hazard. Do not use flammable solutions to clean the air filter.
  - L. The muffler and engine become very hot and can cause a severe burn; do not touch.
- 

## General Safety

---

### **WARNING**

Operating this Wood Chipper safely is necessary to prevent or minimize the risk of death or serious injury. Unsafe operation can create a number of hazards for you.

Always take the following precautions when operating:

- A. Your Wood Chipper is a powerful tool, not a plaything. Exercise extreme caution at all times. The machine is designed to Chip Woods. Do not use it for any other purpose.
- B. Know how to stop the Wood Chipper quickly.
- C. Never operate your unit on a slippery, wet, muddy, or icy surface. Exercise caution to avoid slipping or falling.
- D. See manufacturer's instructions for proper operation and installation of accessories.
- E. Never use the machine without ensuring that all guards and shields are in place.
- F. Never, under any conditions, remove, bend, cut, fit, weld, or otherwise alter standard parts on the Wood Chipper. This includes all shields and guards. Modifications to your machine could cause personal injuries and property damage and will invalidate your warranty.
- G. If the machine start to make an unusual noise or vibrate, shut down the engine, disconnect the spark plug wire, keeping it away from the spark plug to prevent accidental starting, wait 5 minutes for engine to cool down, then inspect for damage. Vibration is generally a warning of trouble. Check damaged parts and clean, repair and/or replace as necessary.

- H. Never tamper with safety devices. Check their proper operation regularly.
  - I. Before performing any maintenance or inspection procedure, shut down the engine, disconnect the spark plug wire keeping it away from the spark plug to prevent accidental starting, wait 5 minutes for machine to cool down.
  - J. Never allow people who are unfamiliar with these instructions to use the Wood Chipper. Allow only responsible individuals who are familiar with these rules of safe operation to use your machine.
  - K. Never overload or attempt to chip woods beyond the manufacturer's recommendation. It could result in personal injury or damage to the machine.
  - L. While using, don't hurry or take things for granted. When in doubt about the equipment or your surroundings stop the machine and take time to look things over.
  - M. Never operate the machine when under the influence of alcohol, drugs, or medication.
  - N. Use the machine only in daylight.
  - O. Stay alert for hidden hazards or traffic.
  - P. Keep all nuts and bolts tight and keep the equipment in good operating condition.
- 

## **A Note to All Users**

List of warnings and cautions cannot be all-inclusive. If situations occur that are not covered by this manual, the operator must apply common sense and operate this WOOD CHIPPER in a safe manner. Contact the dealers for assistance in your area.



# **PART II: Familiar with the Wood Chipper**

---

---

It may be helpful to familiarize yourself with the controls and features of the Wood Chipper. If you have any question, please contact the dealers in your area.

## **TECHNICAL SPECIFICATIONS**

	<b>Recoil Start / Electric Start</b>
<b>Engine</b>	<b>7HP four strokes</b>
<b>Power</b>	<b>Petrol</b>
<b>Chipper Capacity</b>	<b>3CBM/hour to 5CBM/hour</b>
<b>Wood Diameter</b>	<b>diameter 100mm</b>
<b>Chipper Blade</b>	<b>twin reversible blades</b>
<b>Overall Height</b>	<b>1150mm</b>
<b>Overall Length</b>	<b>1850mm</b>
<b>Width</b>	<b>740mm</b>
<b>weight</b>	<b>145kgs</b>
<b>Roller Max RPM</b>	<b>2000rpm</b>
<b>Sound Power Level</b>	<b>118db</b>

## PART III: Operating the Wood Chipper

---

---

Familiarize yourself with the features of your Wood Chipper before beginning the steps outlined in this chapter.

---

### **WARNING**

- A. Read and understand all instructions, safety precautions, and/or warnings listed in “PART I: General Safety Rules” before operating the WOOD CHIPPER. If any doubt or question arises about the correct or safe method of performing anything found in this manual, please contact the dealers in your area.
  - B. When operating the Wood Chipper, make sure you are standing in the safe operating area (OPERATOR ZONE). You must stay in the safe operating area at all times when the ram is in motion (whether extending or retracting). Never place any part of your body into a position that causes an unsafe operating condition.
  - C. Before loading and operating the Wood Chipper, always wear protective gear, including safety goggles, hearing protection, tight-fitting gloves without draw strings or loose cuffs, and steel-toed shoes.
  - D. Knowing the correct and incorrect methods of Chipping woods. Never using an incorrect or unsafe method.
- 

### **Starting**

- 1. Position your Wood Chipper on flat, dry ground, make sure the machine cannot be moved.
- 2. Always check the oil level before starting and top up as needed.
- 3. Make sure the fuel shut-off valve is in the “ON” position.
- 4. Move the choke control lever to the “CHOKE” position (should only be needed if the engine is cold).
- 5. Move the throttle control lever to the “FAST” position.
- 6. Recoil Start: Turn the Ignition Switch to the “On” position. Grasp the recoil starter handle and slowly pull until you feel resistance. Let the cord retract a little bit then pull the cord rapidly to start the engine. One or two pulls usually starts the engine.
- 7. Electric Start (where fitted): Turn and hold the Key in the start position until Engine starts then let the Key return to run position.
- 8. Move the choke control lever (if used for cold engine) slowly back to the “RUN” position when the engine is running well.
- 9. If the Wood Chipper has not been running (cold engine), warm up the engine by running the engine at half throttle for 3 to 4 minutes, then advance the engine throttle control to the maximum speed.

## Stopping

1. Move the Throttle Lever to IDLE.
2. Recoil Start: Turn the Ignition Switch to the OFF position.
3. Electric Start: Turn the Key to the OFF position.

## Operator Zone

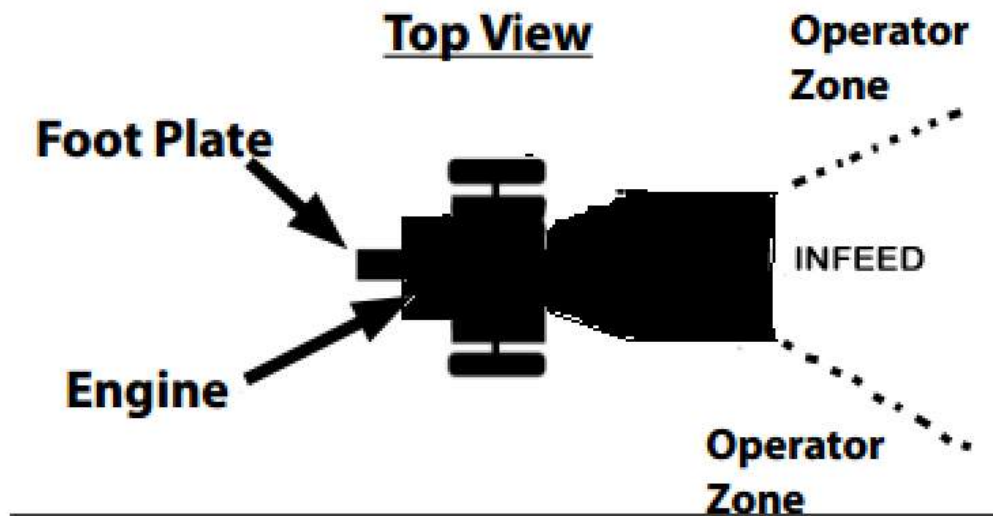

## Wood Chipping

---

### NOTICE

Woods' and branches' diameter should be no bigger than 120mm.

---

---

### WARNING

Do not place your hands into the chute when loading. This is a very UNSAFE method and could result in injury to your hands.

Do not reach or step across the rail while the Wood Chipper is running. This is a very UNSAFE method which could cause personal injury, even death.

---

## When Blocked

If the Roller stops while chipping woods or branches, the engine should be stopped, and take out the woods which stuck the roller, and then restart the engine, and chip again.

## PART IV: Maintaining the Wood Chipper

---

Regular maintenance is the way to ensure the best performance and long life of your machine. Please refer to this manual and the engine manufacturer's user manual for maintenance procedures.

### **WARNING**

Before performing any maintenance procedure or inspection, stop the engine, wait five minutes to allow all parts to cool. Disconnect the spark plug wire, keeping it away from the spark plug. Disconnect the Battery Terminals (Electric start only).

### Regular Maintenance Checklist

Procedure	Before Each Use	Every 3 Hours	Every 25 Hours	Every 100 Hours
Check engine oil level	Δ			
Check general equipment condition	Δ			
Check wedge for sharpness	Δ			
Check belts	Δ			
Check tire pressure			Δ	
Clean engine exterior and cooling			Δ	
Change Engine Oil	First time 5hours		Δ	
Replace air filter			Δ	
Replace spark plug				Δ

### Engine Service

Refer to the engine manufacturer's user manual for engine maintenance. Check before use.

### Lubrication

### **NOTICE**

All Bearings of your Chipper are sealed units and should have sufficient lubricant to last the life of your machine with normal use.

# PART V: Troubleshooting and Parts List

Most problems are easy to fix. Consult the Troubleshooting Table below for common problems and their solutions. If you continue to experience problems, contact the dealers in your area.

## WARNING

Before performing any maintenance procedure or inspection, stop the engine, wait five minutes to allow all parts to cool. Disconnect the spark plug wire, keeping it away from the spark plug.

### Troubleshooting Table

SYMPTOM	POSSIBLE CAUSE
<p><i>The engine won't start.</i></p> <p><i>(Please refer to the engine user manual for engine-specific procedures.)</i></p>	<ul style="list-style-type: none"> <li>➤ <i>Is the ignition switch in the "ON" position?</i></li> <li>➤ <i>Is the fuel shut-off valve on?</i></li> <li>➤ <i>Are you using fresh, clean petrol? If the petrol is old, change it. Use a fuel stabilizer if you keep petrol longer than 30 days.</i></li> <li>➤ <i>Is the spark plug clean? If the spark plug is dirty or cracked, change it. If it's oily, leave it out, hold a rag over the plug hole and pull the recoil cord several times to blow out any oil in the cylinder, then wipe off the plug and reinsert it.</i></li> </ul>
<p><i>The engine lacks power or is not running smoothly.</i></p> <p><i>(Please refer to the engine user manual for engine-specific procedures.)</i></p>	<ul style="list-style-type: none"> <li>➤ <i>Check that the Throttle Lever is in the "Run" position.</i></li> <li>➤ <i>Is the air filter clean? If it's dirty, change it following the procedure in the engine manufacturer's owner's manual.</i></li> <li>➤ <i>Is the spark plug clean? If it's fouled or cracked, change it. If it's oily, leave it out, hold a rag over the plug hole and pull your recoil cord several times to blow out any oil in the cylinder, then wipe off the plug and reinsert it.</i></li> <li>➤ <i>Are you using fresh, clean unleaded petrol? If it's old, change it. Use a fuel stabilizer if you keep petrol longer than 30 days.</i></li> <li>➤ <i>Does your engine have the right amount of clean oil? If it's dirty, change it following the procedure in the engine manufacturer's owner's manual.</i></li> <li>➤ <i>Check the oil level and adjust as needed.</i></li> </ul>
<p><i>Engine smokes.</i></p> <p><i>(Please refer to the engine user manual for engine-specific procedures.)</i></p>	<ul style="list-style-type: none"> <li>➤ <i>Check the oil level and adjust as needed.</i></li> <li>➤ <i>Check the air filter and clean or replace if needed.</i></li> <li>➤ <i>You may be using the wrong oil—too light for the temperature. Refer to your Engine Owner's Manual for detailed information.</i></li> <li>➤ <i>Clean the cooling fins if they're dirty.</i></li> </ul>
<p><i>Not running with full chipping power.</i></p>	<ul style="list-style-type: none"> <li>➤ <i>The belts may be too loose and slipping. Adjust or replace belts as need.</i></li> </ul>

## Explosion View and parts list

Ref.No	Description	Ref.No	Description
.		.	
1	Belt cover	33	Anvil spacing bar
2	Belt	34	Battery box
3	Drive Pulley	35	Battery
4	Drum pulley	36	Bearing cover
5	Spacer	37	Blade
6	Bearing	38	Anvil
7	Seal plate	39	Battery fasten board
8	Inner belt cover	40	Bearing hole cover
9	Washer 8	41	flange
10	Engine	42	Bearing
11	Infeed hopper	43	Bearing seal
12	Press switch fixaton	44	Wheel
13	Press switch	45	Drum
14	Handle	46	space
15	Fitting pipe	47	Wheel axle
16	Emergency stop frame	48	Battery base plate
17	Extension pipe	49	Arch board
18	M10 lock nut	50	Forefoot
19	M10 nut	51	Discharge damping rubber
20	Compression spring	52	Tow bar
21	Infeed extension	53	Foot rubber
22	Rubber layering	54	Tow hitch
23	Rubber	55	Discharge bottom part
24	Restore handle	56	Discharge top part
25	Kill switch	57	Chute adjust
26	Switch cover		
27	Extension spring		
28	Gear plate		
29	Engine fixation plate		
30	Shock cushion holds plastic clasp		
31	Infeed damping pad		
32	Main frame		

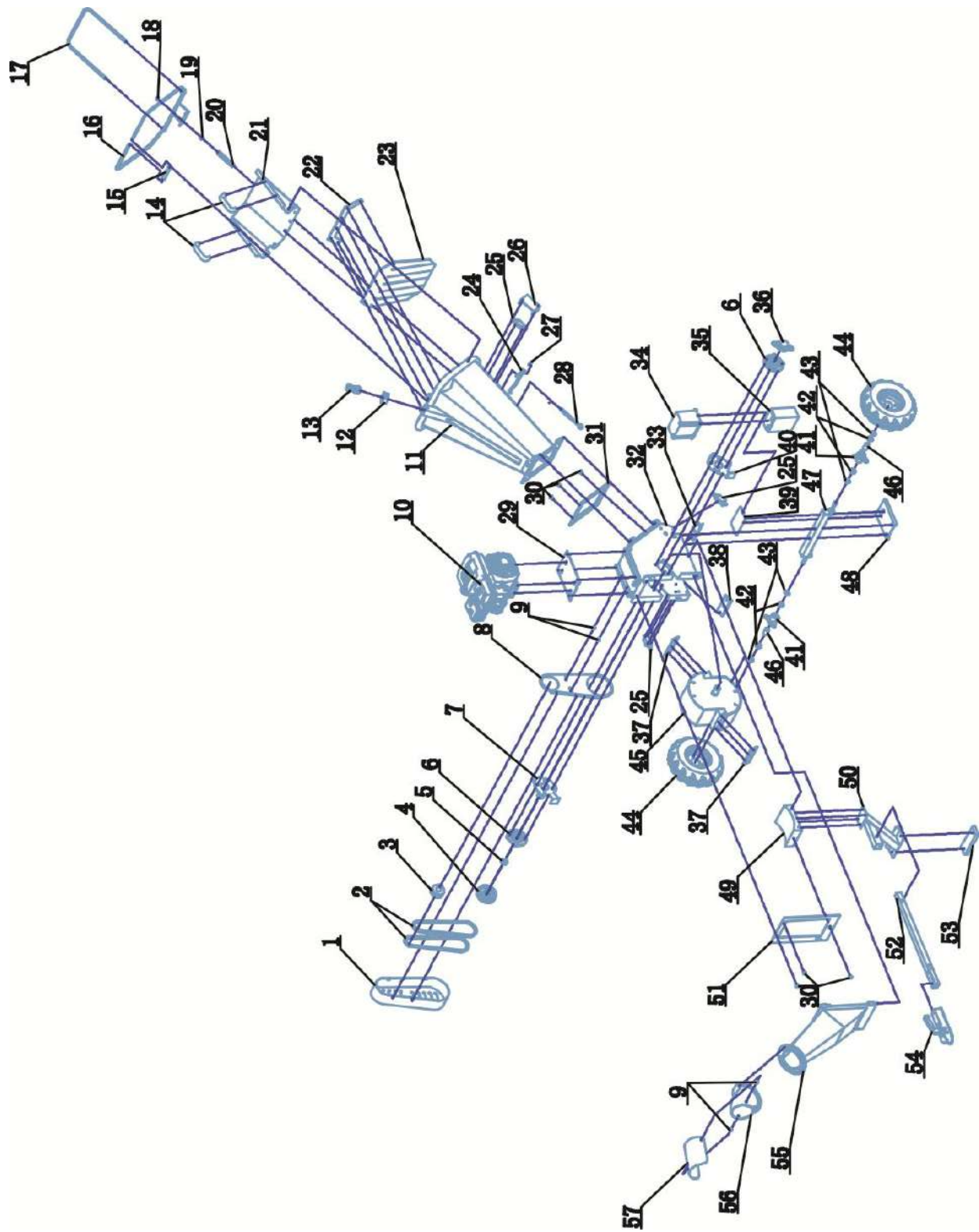

# PART VI: Warranty & Environment

---

---

This product is warranted in accordance with legal regulations for a 24 month period effective from the date of purchase by the first user.

This product will not be covered if used in a commercial application.

This warranty covers all material or production failures, it does not include: defects from normal wear and tear, parts such as, bearings, brushes, cables, air cleaning elements, brake pad, clutch disc, tyre, wheel, recoil starter rope, belts, cutter blades, plugs, lubricant oils and grease or accessories. Damage or defects resulting from abuse, accidents or alterations, natural fading of painted or plated surfaces, sheet peeling and other natural deterioration.

Any damage that occurs from the use of non-genuine Cobra parts will not be covered. We reserve the right to reject any claim where the purchase cannot be verified or when it is clear that the product was not maintained properly. (Clean ventilation slots, carbon brushes and serviced regularly)

Expenses incidental to the warranty claim that are not covered;  
-Compensation for loss of time, commercial loss or rental costs of substitute product.  
-Costs incurred for transportation to and from the dealership.

Any damage that occurs from the following will not be covered; exposure of the product to smoke and soot, chemical agents, bird droppings or other animal waste, seawater, sea breeze, salt or other environmental phenomena.

Any damage resulting from operating methods other than those indicated in the owner's manual will not be covered.

Your purchase receipt must be kept as proof for date of purchase. Your un-dismantled product must be returned to your dealer in an acceptably clean state, accompanied by your proof of purchase.

## **ENVIRONMENT**

Should your machine need replacement after extended use, do not put it in the domestic waste but dispose of it in an environmentally safe way.



# PART VII: Assembly Instructions

---



1. Remove from packing & fitting the wheel axle.  
Use a block to support whilst securing and fitting the axle for the transport wheels.



2. Wheel split pins fitting.  
Fit with split pins just tight enough to get split pins in.



3. Fit the intake hopper  
Fit the intake hopper and secure the bolts.



4. Fit the front resting plate.  
Secure the front support with the bolts provided.

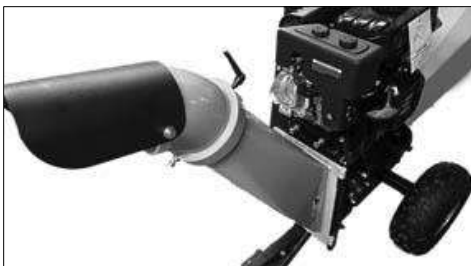

5. Fit the exit/discharge shoot  
The shoot is fitted with 4 bolts – ensure these are fully tightened and secure.



6. Fit the tow bar to the front resting plate with the bolts provided, fully tighten and ensure securely fitted.



7. Install the intake extension chute and intake extension bar

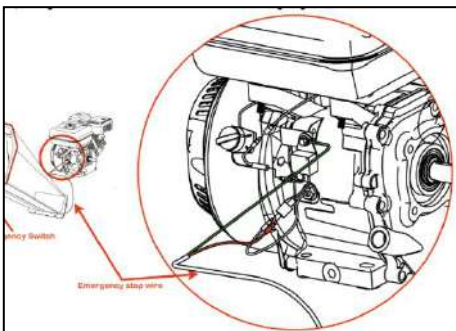

8. Attach the emergency stop wire.  
Before operating fit the emergency stop wire. Check the engine stops correctly before operating in every case.



**Add engine oil as per the engine manufacturers instructions. The engine is shipped without oil.**

## EC-DECLARATION OF CONFORMITY

EC Declaration of Conformity	
We herewith declare,	Cobra Garden Machinery Henton & Chattell Ltd, London Road, Nottingham NG2 3HW United Kingdom
That the following machine complies with the appropriate basic safety and health requirements of the EC Directive based on its design and type, as brought into circulation by us.	
In case of alteration of the machine, not agreed upon by us, this declaration will lose its validity	
Machine Description:	Petrol Wood Chipper
Machine Type:	CHIP700L (DR-GS-350H)
Displacement	212cm <sup>3</sup>
Max. Operating Width:	100mm
Measured sound power level:	110dB(A)
Guaranteed sound power level:	118dB(A) Notified Body for EC Directive 2000/14/EC Annex V & 2005/88/EC SGS-CSTC Standards Technical Services (Shanghai) No.588 West Jindu Road, Songjiang District, Shanghai, China
Applicable EC Directives:	2006/42/EC      2014/30/EU 2000/14/EC      97/68/EC
Applicable Harmonized Standards:	EN ISO 12100:2010 EN 13683:2003+A2:2011+AC:2013 EN ISO 14120:2015 EN ISO 13857:2008 EN ISO 14982:2009
Authorized Signature/Date/ Place:	 Peter J. Chaloner 11/4/2022
Title of Signatory:	Managing Director
Name and address of the person authorised to compile the technical file	Cobra Garden Machinery Henton & Chattell Ltd, London Road, Nottingham NG2 3HW United Kingdom